

Eclipse RatioMatic

Burners

Model RM0050

Version 5

Parameter		Specification	
Blower Type	Chamber Pressure "w.c. (mbar)	50 Hz	60 Hz
Maximum Input, Btu/h (kW)¹ <i>Contact factory for chamber pressures outside the given range, or varying chamber pressure conditions.</i>	-5.0 (-12.4)	660,000 (195)	650,000 (190)
	-3.0 (-7.5)	610,000 (180)	600,000 (175)
	0 (0.0)	520,000 (150)	500,000 (150)
	1.0 (2.5)	490,000 (145)	460,000 (135)
	2.0 (5.0)	450,000 (130)	420,000 (125)
Minimum Input On-Ratio, Btu/h (kW)²	with high turndown ratio regulator	20,000 (6)	
	with standard ratio regulator	30,000 (9)	
Main Gas Inlet Pressure, "w.c. (mbar)³ <i>Fuel pressure at ratio regulator inlet</i>	12 to 50 (30 to 125)		
High Fire Flame Length, inches (mm) <i>Measured from the outlet end of the combustor</i>	24 (600)		
Maximum Chamber Temperature, °F (°C)	Alloy Tube	1500 (815)	
	SiC Tube	1900 (1038)	
Flame Detection	Flame rod or UV Scanner		
Fuel⁴ <i>For any other mixed gas, contact Eclipse, Inc.</i>	Natural Gas, Propane, Butane		
Blower Motor Power, Hp (kW)	0.25 (0.18)		
Weight, lbs (kg)⁵	84 (38)		
Approvals	 АИЗ0		

¹ Maximum inputs for packaged blower versions are given for the standard combustion air blower without an inlet air filter.

² Turndown input based on neutral chamber conditions. Contact Eclipse for other chamber pressures.

³ For proper performance, this pressure must be kept constant across the burner operating range.

⁴ See Design Guide 110 for more information about typical fuel composition and properties.

⁵ All weights are approximate.

- All information is based on laboratory testing. Different chamber conditions will affect the data.
- All inputs based upon gross calorific values and standard conditions; 1 atmosphere, 70°F (21°C).
- Eclipse reserves the right to change the construction and/or configuration of our products at any time without being obliged to adjust earlier supplies accordingly.

Performance Graphs

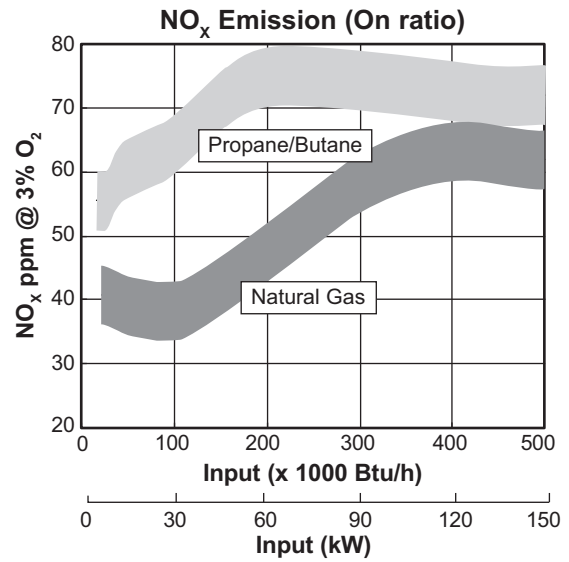
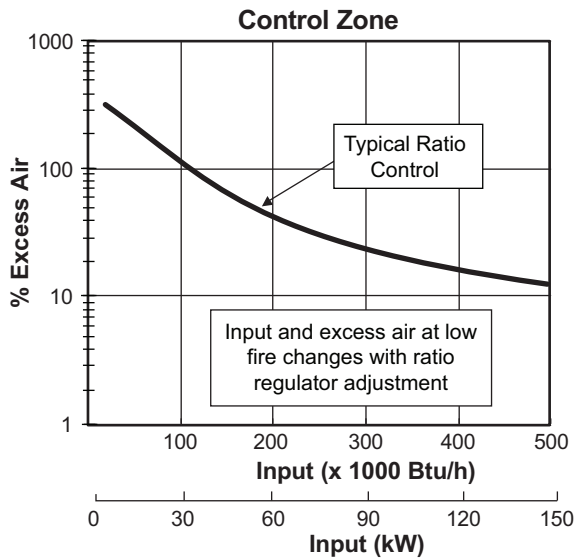

NO_x Emission data is given for:

- Ambient combustion air ~70°F (21°C)
- Less than 700°F (370°C) firing chamber
- Minimal process air velocity
- Low fire input adjusted to 20,000 Btu/h (6 kW)
- ppm volume, dry @ 3% O₂
- Neutral chamber pressure

Emissions from the burner are influenced by:

- Chamber conditions
- Fuel type
- Firing rate
- Ratio regulator adjustment
- Combustion air temperature

CO emission is largely influenced by chamber conditions. Contact your local Eclipse representative for an estimate of CO emission on your application.

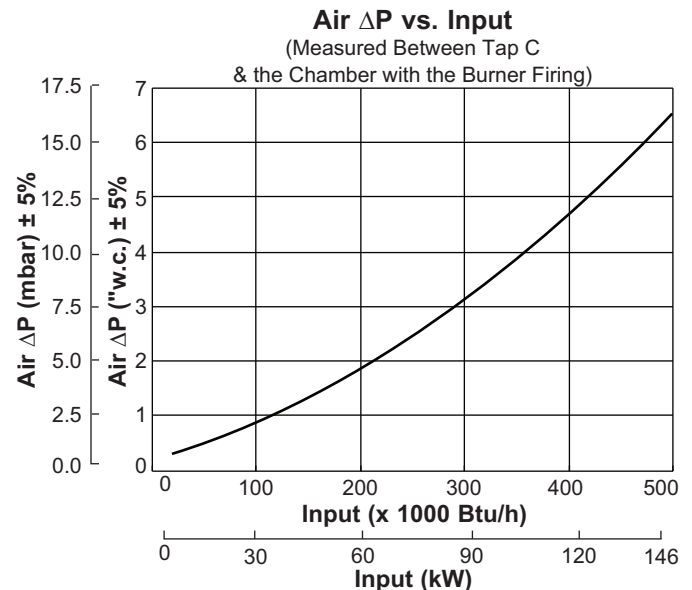
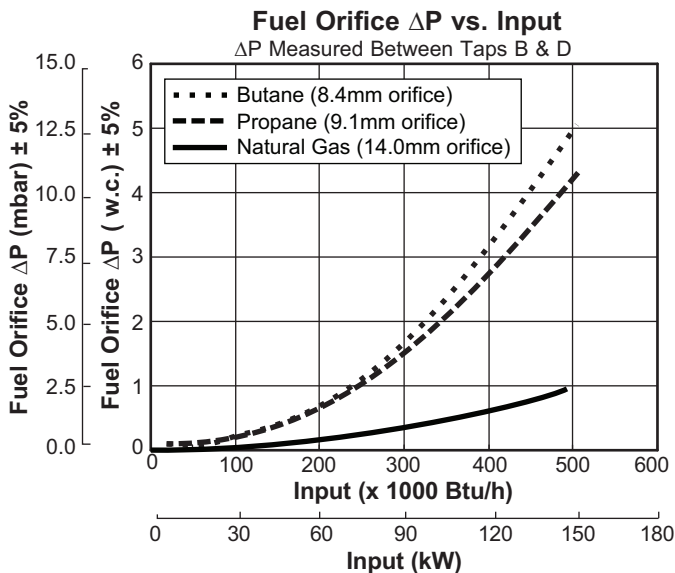

Dimensions & Specifications

Dimensions in mm (in)

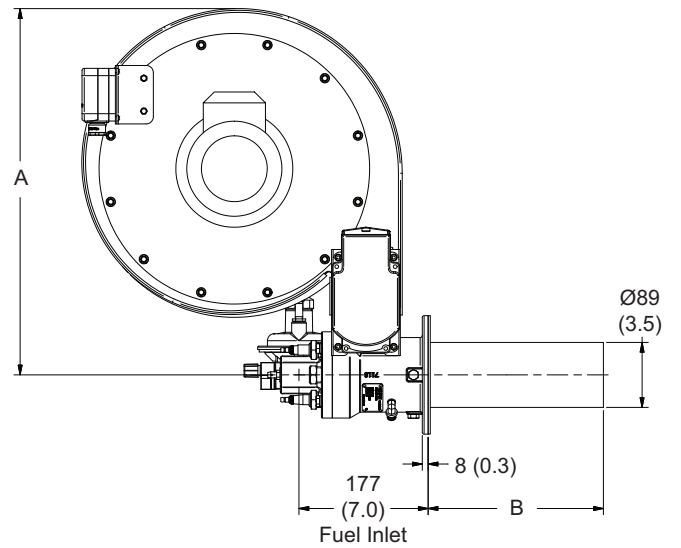
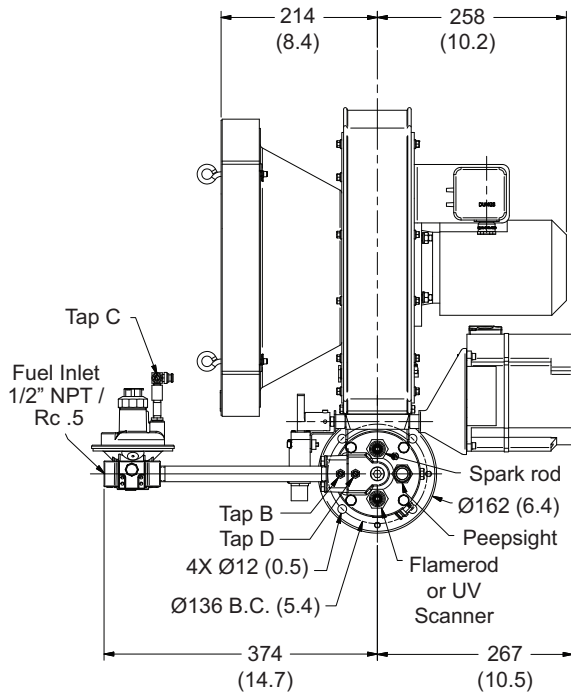

Blower Size	A
50 Hz	501 (19.7)
60 Hz	445 (17.5)

Combustor Type	B
Straight Stainless Steel Alloy/Silicon Carbide Tube	240 (9.5)
Straight Stainless Steel Alloy Tube	315 (12.4)
Straight Stainless Steel Alloy Tube	390 (15.4)

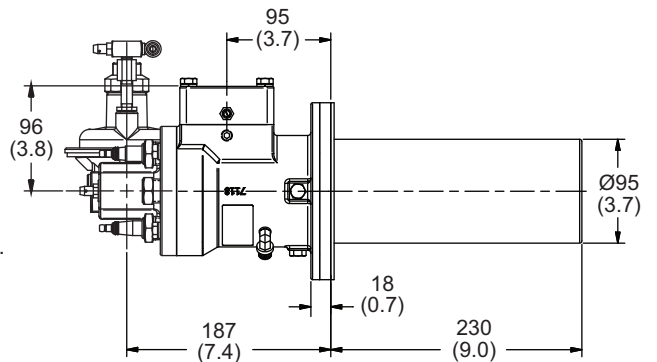
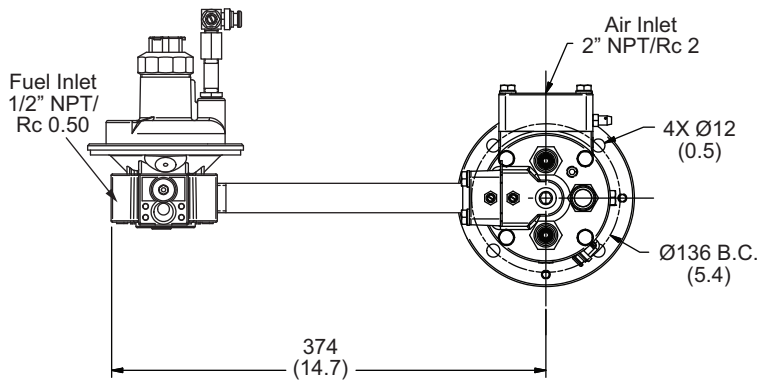

Shown with Silicon Carbide
Combustor and Flange

Combustor Options

Alloy Combustor

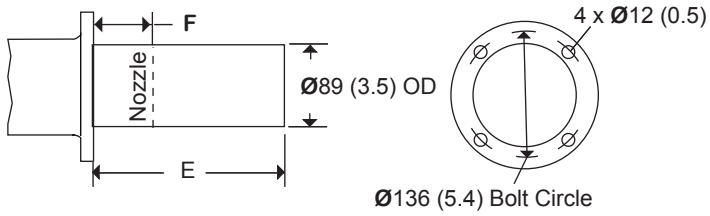

Silicon Carbide Combustor

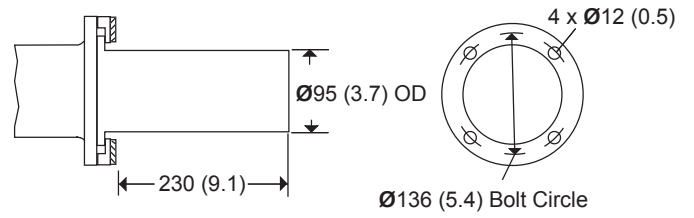

E	F
240 (9.5)	83.5 (3.3)
315 (12.4)	159.5 (6.3)
390 (15.4)	235.5 (9.3)

Burner Configuration

Inverted Left Hand Piping

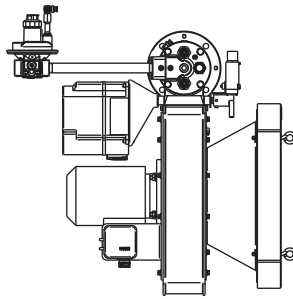

Inverted Right Hand Piping

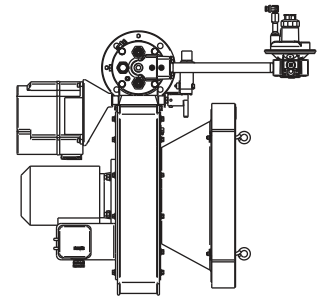

Upright Left Hand Piping

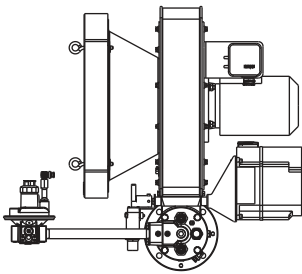

Upright Right Hand Piping

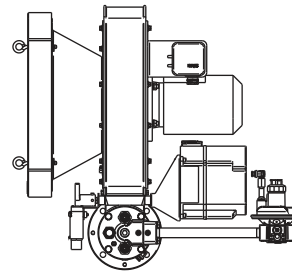

Offered By:

Power Equipment Company

2011 Williamsburg Road Richmond, Virginia 23231

Tel: 804-236-3800 Fax: 804-236-3882 www.peconet.com